

Working Instructions Translation

Heating Element Butt Welding Machine

WIDOS 4400



Keep for further use!

Model:	Heating element butt welding machine
Type:	WIDOS 4400
Serial number / year of construction:	see type lable

Customer entries

Inventory-No.:	
Place of working:	

Order of spare parts and after sales service:

Address of manufacturer

WIDOS

Wilhelm Dommer Söhne GmbH
Einsteinstrasse 5

D-71254 Ditzingen

Phone: ++49 7152 99 39 0

Telefax: ++49 7152 99 39 40

Purpose of the document

These working instructions give you information about all important questions which refer to the construction and the safe working of your machine.

Just as we are, you are obliged to engage in these working instructions, as well.

Not only to run your machine economically but also to avoid damages and injuries.

Should questions arise, contact our service teams in the factory or in our subsidiary companies.

We will help you with pleasure.

According to our interest to continuously improve our products and working instructions, we kindly ask you to inform us about problems and defects which occur during exercise.

Thank you.

Structure of the working instructions

This manual is arranged in chapters, which belong to the different using phases of the machine.

Due to this structure, the searched information can be easily found.



© WIDOS 16.05.2019

Wilhelm Dommer Söhne GmbH

Einsteinstraße 5

D-71254 Ditzingen

All rights reserved.

Reprinting only allowed with permission of the corporation.

Any changes prior to technical innovations.

1. DESCRIPTION OF THE PRODUCT	6
1.1. Usage and purpose oriented use.....	6
1.2. Safety measures	6
1.3. Conformity	6
1.4. Machine overview	7
1.5. Designation of the product.....	7
1.5.1. Technical data	7
1.5.1.1. WIDOS 4400 General data.....	7
1.5.1.2. Heating element.....	8
1.5.1.3. Planer.....	8
1.5.1.4. Hydraulic aggregate.....	9
1.5.1.5. Basic frame	9
1.5.1.6. Reception box.....	9
1.6. Equipment and accessories:	9
2. SAFETY RULES.....	10
2.1. Explanation of the symbols and indications.....	10
2.2. Obligations of the owner	11
2.3. Obligations of the worker.....	11
2.4. Measures of organisation	11
2.5. Information about safety precautions.....	11
2.6. Instructions for the staff	11
2.7. Dangers while handling the machine	12
2.8. Danger caused by electric energy	12
2.9. Dangers caused by the hydraulic aggregate	12
2.10. Specific dangers.....	13
2.10.1. Danger of catching clothes by the planer.....	13
2.10.2. Danger of being burnt by heating element, reception box and welding area	13
2.10.3. Danger of stumbling over hydraulic and electric wires	13
2.10.4. Danger of squeezing by clamping devices and guideways.....	13
2.11. Structural modifications on the machine	14
2.12. Cleaning the machine	14
2.13. Warranty and liability	14
3. FUNCTIONAL DESCRIPTION.....	15
4. OPERATING AND INDICATING ELEMENTS	16
4.1. Elements on the aggregate	16
4.1.1. Hydraulic aggregat with pressure gauge analog.....	17
4.2. Elements on the side of the aggregate	17
4.3. Elements at planer and heating element	18

5. STARTING AND OPERATING	19
5.1. Starting	19
5.1.1. Replacing the reduction inserts.....	20
5.1.2. Using small and large reduction inserts	20
5.2. Welding process.....	21
6. WELDING LOG AND TABLES	23
7. MAINTENANCE AND REPAIR.....	25
7.1. Maintenance and inspection, repair.....	25
7.2. Clamping elements	25
7.3. Planer.....	25
7.4. Storage.....	25
7.5. Used hydraulic oil.....	25
7.6. Checking the hydraulic oil-level	26
7.7. Venting the hydraulic cylinders.....	26
8. TRANSPORT	27
9. HYDRAULIC AND ELECTRIC DIAGRAMS	28
10. SPARE PARTS LIST	31
11. DECLARATION OF CONFORMITY	32

1. Description of the product

This chapter gives important basic information about the product and its prescribed use. All technical details of the machine are put together as a general arrangement.

1.1. Usage and purpose oriented use

The **WIDOS 4400** has been designed only for heating element butt welding of pipes and fittings with a diameter range of $\varnothing = 50 - 160$ mm (standard diameters: 50 / 63 / 75 / 90 / 110 / 125 / 140 / 160 mm).

It is a building site machine and is designed especially for the use on site as well as in the workshop. For this reason, the frame is kept small such that it can be used also in constrained positions (e.g. building ditches).

All use going beyond is not purpose oriented.

The manufacturer is not responsible for any damages caused by inexpert handling or operation.

For personal injuries, material and immaterial damages resulting herefrom, only the user is responsible!

Also part of the purpose oriented use is

- respecting all the indications of the working instructions and
- performing the inspection and maintenance works.

1.2. Safety measures

In case of wrong use, wrong operation or wrong maintenance, the machine itself or products standing nearby can be damaged or destroyed.

Persons being in the endangered area may be injured.

Therefore these working instructions have to be thoroughly read and the corresponding safety regulations must be necessarily adhered to.

1.3. Conformity

The machine corresponds in its construction to the valid recommendations of the European Community as well as to the according European standard specifications.

The development, manufacturing and mounting of the machine were made very carefully.

1.4. Machine overview

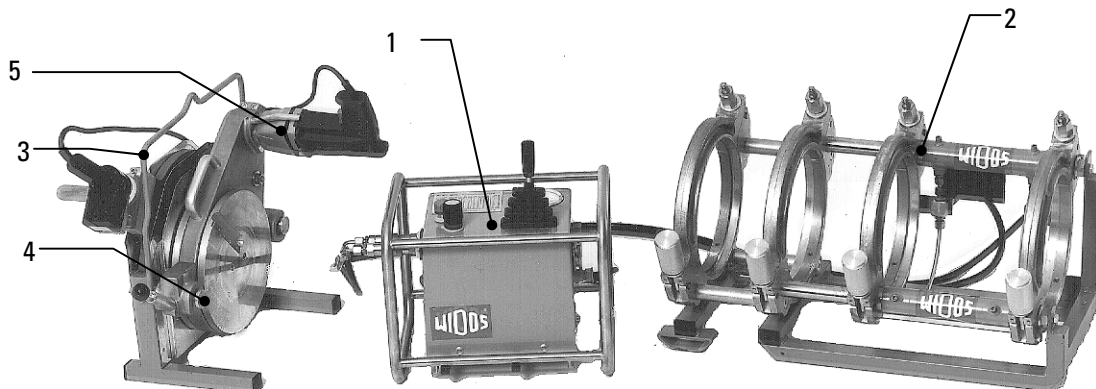

No.	Description
1	Hydraulic aggregate
2	Basic machine with clamping devices
3	Heating element
4	Reception box
5	Planer

1.5. Designation of the product

The product is designated by two type labels.

The type labels are attached at the aggregate and at the basic machine.

They contain the type, the serial number and the year of construction of the machine.

1.5.1. Technical data

1.5.1.1. WIDOS 4400 General data

Material:	PE, PP, PVDF,
Pipe diameter range::	outside- \varnothing = 50 – 160 mm
Packing box (l x w x h):	appr. 820 x 680 x 750 mm
Weight:	appr. 14 kg
Weight (without boxes):	appr. 60 kg
Protection:	10 A
Wire cross section:	1,5 mm ²
Emissions	<ul style="list-style-type: none"> - Noises exceeding 80 dB (A) may occur; during planing it is obligatory to wear ear protection! - When using the named pipe materials and when welding below 260 °C / 500 °F no toxicant damp arises.

Environmental conditions at the welding area:	<ul style="list-style-type: none"> - Keep the workshop clean (no dust at the welding area) - If secured by an appropriate measurement that allowed conditions for welding are indicated, it is possible to work in any outside temperature condition as far as the welder is not constrained in its manual skill. - Avoid humidity, if necessary use a welding tent - Avoid strong sun rays influence - Protect from wind, shut the pipe ends.
---	---

1.5.1.2. Heating element

Power:	800 Watt
Voltage:	230 V ($\pm 10\%$)
Current:	3,5 A ($\pm 10\%$)
Frequency:	50 Hz
Outside- \varnothing :	200 mm
Surface:	Nonstick-coated
Attached elements:	<ul style="list-style-type: none"> - Electronic temperature control - On / off switch red illuminated - Control lamp green - Connecting cable and plug
Weight:	appr. 3,5 kg

1.5.1.3. Planer

Motor:	Monophase-alternating current-motor
Power:	950 Watt
Voltage:	230 V ($\pm 10\%$)
Current:	4,1 A
Frequency:	50 Hz ($\pm 10\%$)
RPM n of planer:	100 rpm
Attached elements:	<ul style="list-style-type: none"> - Switch on/off with fixing device - Connecting cable and plug
Weight:	appr. 7,5 kg

1.5.1.4. Hydraulic aggregate

Power:	0,315 kW
Voltage:	230 V (± 10 %)
Current:	1,5 A
Frequency:	50 Hz
Phase shift:	appr. 18°
Hydraulic fluid tank:	appr. 1 L
System of protection:	IP 54
Electro motor and pump:	
Rotation speed:	1380 rpm
Max. working pressure of pump:	appr. 120 bar
Working pressure:	100 bar
Volume velocity:	1,0 L/min
Weight:	23 kg

1.5.1.5. Basic frame

Dimension (l x w x h):	600 x 320 x 300 (mm)
Reductions insert:	Dimension upon request
Material of frame:	Construction steel
Material of reduction inserts:	Aluminium
Weight:	25 kg
∅ of cylinder:	28 mm
∅ of piston rod:	25 mm
Length of stroke of cylinder:	100 mm
max. force (F=P*A):	2500 N (at 100 bar)
Velocity of piston rod:	6,7 cm/s

1.5.1.6. Reception box

Weight:	appr. 4,0 kg
---------	--------------

For article numbers and component parts see spare parts list

1.6. Equipment and accessories:

The following accessories are part of the first delivery:

1	Tool bag for 10 parts
1	Socket spanner size 24
1	Torx screw driver T10
1 each	Allen key angulate size 3 / 5 / 6
1 each	Allen key with T grip size 3 / 4
option	Reduction inserts (large, extra large), roller brackets for the pipes, transformer

2. Safety rules

The base for the safe handling and the fault-free operation of this machine is the knowledge of the basic safety indications and rules.

The security notices of this chapter represent the general part.

Particular indications are listed directly at the description of the corresponding actions.

- These working instructions provide you with the most important information to run the machine safely.
- The safety indications must be read by all persons working on the machine.

2.1. Explanation of the symbols and indications

In the working instructions, following denominations and signs are used for dangers:



This symbol means a possibly danger for the life and the health of persons.

- The disrespect of these indications may have heavy consequences for the health.



This symbol means a possible dangerous situation.

- The disrespect of these indications may cause slight injuries or damages on goods.



This symbol means a possible dangerous situation by moving parts of the machine

- The disrespect of these indications may cause heavy crushings of parts of the body resp. damages of parts of the machine.



This symbol means a possible dangerous situation due to hot surfaces.

- The disrespect of these indications may conduct to heavy burns, respectively to self-ignition or even fire.



This symbol gives important indications for the proper use of the machine.

- The disrespect of these indications may conduct to malfunctions and damages on the machine or on goods in the surrounding.



Under this symbol you get user tips and particularly useful information.

- It is a help for using all the functions on your machine in an optimal way and helps you to make the job easier.

The regulations for the prevention of accidents are valid (UVV).

2.2. Obligations of the owner

The owner is obliged only to let persons work at the machine, who

- know about basic safety and accident prevention rules and are instructed in the handling of the machine, as well as who
- have read and understood the safety chapter of this manual and certify this with their signature.

The safety-conscious working of the staff has to be checked in regular intervals.

2.3. Obligations of the worker

All persons who are to work at the machine are obliged before working:

- to follow the basic safety and accident protection rules.
- to have read and understood the safety chapter and the warnings in this manual and to confirm by their signature that they have well understood them.
- to inform themselves about the functions of the machine before using it.

2.4. Measures of organisation

- All equipment required for personal safety is to be provided by the owner.
- All available safety equipment is to be inspected regularly.

2.5. Information about safety precautions

- The working instructions have to be permanently kept at the place of use of the machine. They are to be at the operator's disposal at any time and without effort.
- In addition to the manual, the common valid and the local accident protection rules and regulations for the environmental protection must be available and followed.
- All safety and danger indications on the machine have to be in a clear readable condition.
- Every time the machine changes hands or is being rented to third persons, the working instructions are to be sent along with and their importance is to be emphasized.

2.6. Instructions for the staff

- Only skilled and trained persons are allowed to work at the machine.
- It must be clearly defined who is responsible for transport, mounting and dismounting, starting the operation, setting and tooling, operation, maintenance and inspection, repair and dismounting.
- A person who is being trained may only work at the machine under supervision of an experienced person.

2.7. Dangers while handling the machine

The machine **WIDOS 4400** is constructed according to the latest technical standard and the acknowledged technical safety rules. However, dangers for the operator or other persons standing nearby may occur. Also damages to the machine itself or to other things are possible.

The machine may only be used:

- according to the purpose-oriented usage
- in safety technical impeccable status

Disturbances, which may affect the safety of the machine must be eliminated immediately.

2.8. Danger caused by electric energy



Only skilled persons are allowed to work at electrical appliances !

- The electrical equipment of the machine has to be checked regularly.
- Loose connections and damaged cables have to be replaced immediately.
- If works at alive parts are necessary, a second person has to assist who can disconnect the machine from the mains if necessary.
- All electric tools (heating element, planer and aggregate) have to be protected from rain and dropping water (if need be use a welding tent).
- According to VDE 0100, the use on construction sites is only allowed with a power distributor with a FI-safety switch.

2.9. Dangers caused by the hydraulic aggregate



System parts and pressure hoses should be made pressureless before beginning of any repair works. Even if the machine is switched off, pressure may be in the hydraulic accumulator!

There is a danger of injuring the eyes by hydraulic oil squirting out.

- Damaged hydraulic hoses have to be immediately replaced.
- Make a visual inspection of the hydraulic hoses before each work beginning.
- The hydraulic oil is inedible !

2.10. Specific dangers

2.10.1. Danger of catching clothes by the planer



You can cut yourself or even get bones broken!

- Only wear clothes tight to the body.
- Do not wear rings or jewellery during the work.
- If necessary, wear a hair-net.
- Always put the planer back into the reception box after and before each use.
- Transport the planer at the handle only.
- Do not touch the planer surfaces.
- Switch the planer on only for usage. Otherwise the planer will start every time when the security microswitch is pressed.

2.10.2. Danger of being burnt by heating element, reception box and area

welding



You can burn yourself, inflammable materials can be ignited!

The heating element temperature gets over **200 °C / 392 °F!**

- Do not touch the surface of the heating element.
- Do not leave the heating element unsupervised.
- Take enough safety distance to inflammable materials.
- Do wear safety gloves.
- Always put the heating element back into the reception box after and before each use.
- Transport the heating element at the holder only.

2.10.3. Danger of stumbling over hydraulic and electric wires

- Make sure that no person has to step over the wires.
- Lay the wires in such a way that the danger is kept to a minimum.

2.10.4. Danger of squeezing by clamping devices and guideways



There is a danger of serious injuries:

on the one hand between the inner clamping devices and on the other hand between the outside clamping device and the end of the guideway.

- Do not stand or put hands between clamped pipe ends.
- Do not stand or put hands between the inner clamping tools with not yet clamped pipes.
- Do not block opening and closing of the machine slides.

2.11. Structural modifications on the machine

- No modifications, extensions or reconstructions may be made on the machine without permission of the manufacturer.
- Machine parts which are not in a perfect condition are to be replaced immediately.
- Only use original **WIDOS** spare and wear parts.
- In case of purchase orders please always state the machine number.

2.12. Cleaning the machine

The used materials and tissues are to be handled disposed of properly, especially

- when cleaning with solvents
- when lubricating with oil and grease

2.13. Warranty and liability

Our „General Sales and Delivery Conditions“ are principally valid.

They are at the owner's disposal at the latest when signing the contract.

Warranty and liability demands referring to damages of persons or objects are suspended if they are caused by one or several of the following reasons:

- not using the machine according to the prescriptions
- improper transport, building-up, starting and operating the machine and maintenance
- operating the machine with defective or improperly installed security measures
- ignoring the information given in this manual
- structural changes at the machine without permission
- unsatisfactory checking of machine parts which are worn out
- repairs performed in an inexpert way
- catastrophes by external influence and Acts of God.

3. Functional description

Basically the international and national standard specifications are to be followed.

The plastic pipes are clamped in the clamping devices. Then the front sides of the pipes are cut plane and parallel by means of the **planer** and the misalignment of the pipes is checked.

The cleaned and heated heating element is inserted and the pipes are pressed against the heating element under defined adjusting pressure. This process is called "**adjusting**".

After the prescribed bead height being reached, pressure is reduced, the **heating time** begins. The function of this time is to heat up the pipe ends.

After expiration of the heating time, the slides are opened, the heating element is removed quickly and the pipes are driven together again. The time gap from the removal of the heating element to joining the pipes is called **change over time**.

The pipes are joined under prescribed welding pressure and then cool down under pressure (**cooling time**).

The welded joint can be unclamped, the welding process is finished.

Heating element heats the pipes up
to welding temperature

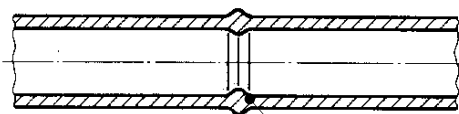
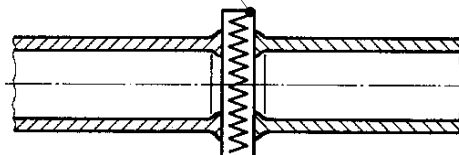

Finished welding with
internal and external bead

4. Operating and indicating elements

4.1. Elements on the aggregate



No.	Denomination	Function
6	Manometer, digital	Display of the hydraulic pressure
7	Valve lever	Opening the slides. There are 4 different positions: - to the left side : slides close. - in the middle (usual position): the pressure which is currently achieved is kept (also by means of the built-in hydraulic accumulator) - slightly to the right side (position pressureless): a possibly existing pressure is released without moving the slides. Due to the hydraulic accumulator, it takes about 10 s until the pressure is completely released. - to the right side : slides open
8	Setting screw for pressure relief valve	- Limitation of the pressure to the desired value
9	Hydraulic connection for closing the slides	- Non-dropping quick-acting coupling
10	Hydraulic connection for opening the slides	- Non-dropping quick-acting coupling
11	Screw with oil dipstick	- checking the oil level - oil filler neck

4.1.1. Hydraulic aggregate with pressure gauge analog



4.2. Elements on the side of the aggregate

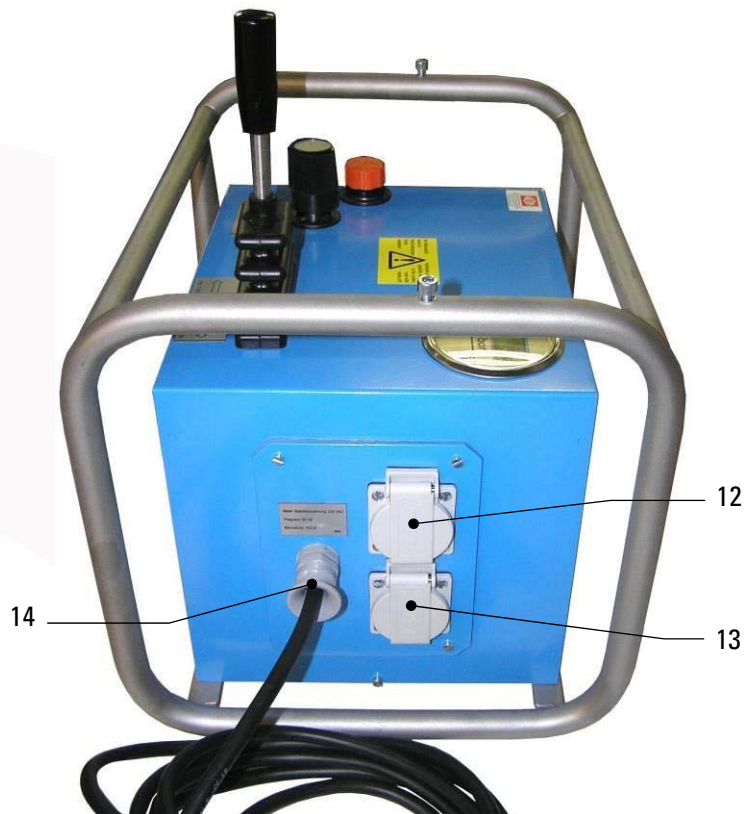

No.	Denomination	Function
12	Socket 230V/50 Hz	Possibility for connecting the planer / heating element
13	Socket 230V/50 Hz	Possibility for connecting the planer / heating element
14	Mains cable 230V/50Hz	Power supply

4.3. Elements at planer and heating element



No.	Denomination	Function
15	On/off switch	- For switching on/off the planer. - Planing is only possible if the security micro switch is pressed
16	Security micro switch	- Protection against unintended running of the planer
17	Locking lever	- Protection of the planer against jumping out of the machine.
18	On/off switch with lamp	- As soon as the heating element is switched on, the red control lamp lightens
19	Setting screw	- For regulating the temperature of the heating element
18	Control lamp green	- There are three different states: <ul style="list-style-type: none"> • off: signalizes that the heating element is not heated up at the moment or that it cools down • blinking: the heating element temperature is maintained by a certain pulse-position ratio • on: signalizes that the heating element is heated up at the moment. It has not yet reached the desired temperature

5. Starting and operating

The instructions of this chapter are supposed to initiate in the operation of the machine and to lead during the appropriate starting of the machine.

This includes:

- the safe operation of the machine
- using all the possibilities
- running the machine economically

5.1. Starting



The machine may only be operated by initiated and authorized persons.

For the qualification, a plastic welding exam can be taken according to DVS and DVGW.

In situations of danger for persons and the machine, the mains plug has to be unplugged immediately.

In case of power failure, there may still be pressure in the hydraulic system. For this reason, release pressure if need be.

After completion of the welding work and during breaks the machine has to be switched off. Further take care that no unauthorized person has access.

Protect the machine from wetness and humidity !

According to VDE 0100, the use on construction sites is only allowed with a power distributor with a FI-security protective switch.



Check the oil level of the hydraulic system before each starting of the control unit in order to avoid damages on the pump. The oil-level must be between the two marks at the oil dipstick.

- Connect the hydraulic aggregate to the mains (230 V / 50 Hz).
- Connect heating element and planer to the corresponding socket at the aggregate.
- Push the hydraulic hoses of the basic machine into the quick-acting couplings of the hydraulic aggregate.



Lay hydraulic and electric lines carefully (danger of stumbling) !

- Take into account the surrounding conditions:
 - The welding may not be performed under direct sun rays influence,
 - If necessary use a welding umbrella.
- If the surrounding temperature is under 5 °C / 41 °F, measures have to be taken:
 - Use a welding tent or preheat the pipe ends if necessary.
- In addition, take measures against rain, wind and dust.

5.1.1. Replacing the reduction inserts

- Unscrew the mounted reduction inserts by means of the provided Allan key.
- Screw the reduction inserts with the corresponding diameter into the clamping devices.
- If necessary (e.g. for T-pieces) the outer fixed clamping device can be dismantled by unscrewing the three hexagon socket screws.

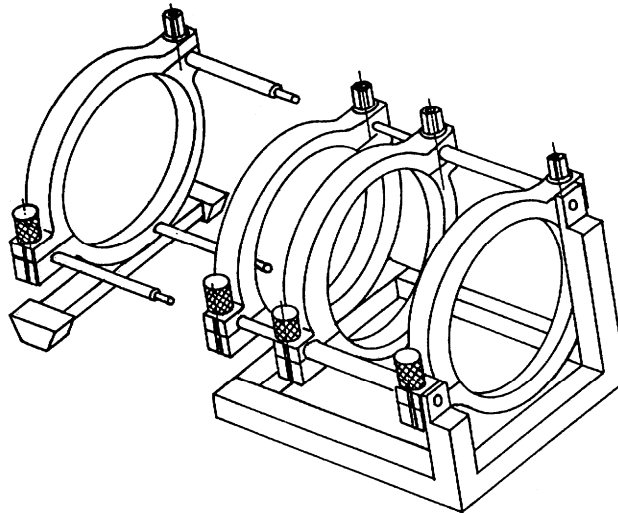

Dismantling of the outer fixed clamping device

5.1.2. Using small and large reduction inserts

Small reduction inserts:

- Pipe fittings often have only a short straight surface area on which they can be clamped.
- Fittings mostly need to be clamped in the inner clamping devices with the small reduction inserts.
- When fittings are to be welded (bends, T-pieces etc.), the inner small reduction insert can also be used flush to the inside or to the outside.

Shown here:
Small reduction insert,
flush to the inside
(for bends, T-pieces)

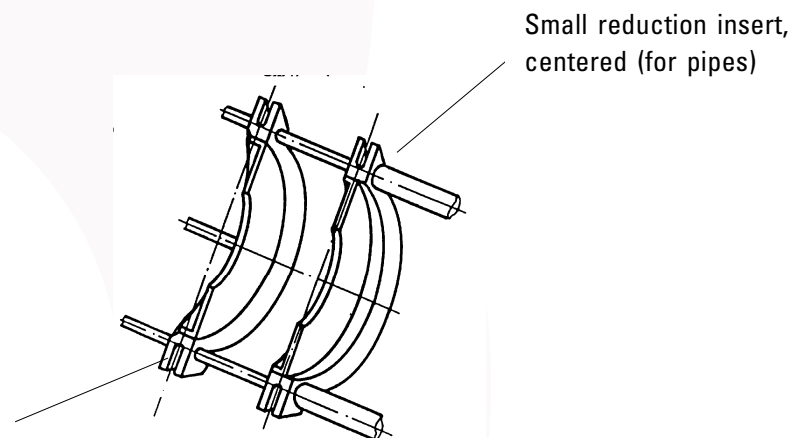

Large reduction inserts

- They are mainly used for a good tightening and are generally mounted on the inner clamping devices.
- Super large reduction inserts have a specially high guidance quality and are mainly used during the welding of fittings with long legs which can only be clamped with a single clamping device.

5.2. Welding process

The respectively valid welding prescriptions (ISO / CEN / DVS...) are to be basically followed.



There is the danger of serious bruising.

On the one hand between the inner clamping devices, on the other hand between the outer clamping device and the end of the guide bar.

- Do wear safety gloves as a protection against burning!
- A stop-watch must be available for recording the actual times for the heating and cooling.
- A welding table must be available from which the parameters for the pipe dimensions to be welded prescribed by the welding prescriptions may be taken.
- The heating element surfaces have to be clean and, above all, free from grease.
For this reason they have to be cleaned with non-fraying paper and detergent (e.g. PE - cleaner) before every welding or if they are dirty.
The anti-adhesive coating of the heating element has to remain undamaged in the working area.
- Switch on the heating element and set the required welding temperature (standard value for PE 80: 210 °C / 410 °F) at the adjusting screw at the handle.
- When the control light is blinking, the desired temperature is obtained and maintained by a certain pulse-position ratio.
- Screw in the reduction inserts according to the outside diameter of the pipes to be welded.
- Lay the pipes to be welded into the clamping devices, tighten firmly the clamping nuts and align the pipes with respect to one another.
In case of long pipe ends, use WIDOS rollerstands for alignment.
- Close the slides, valve lever on: "FORWARDS", thereby reading the **movement pressure** on the manometer.
The movement pressure is displayed exactly when the slide with the clamped-pipe passes over into its movement.
Subsequently, open slides again, valve lever on: "BACKWARDS", such that the planer fits therebetween.
- Insert the planer between the pipe ends, allow handle to lock with the security micro switch and switch on.



There is the danger that the planer pulls in clothes !

In case planer is switched on it will run immediately as soon as the security micro switch is pressed.

Do not hold the planer on its front sides in any case.

- Move the pipe ends towards one another, valve lever on: "FORWARDS", and plane same with a planing pressure between 1 and 15 bar above the movement pressure.
Planing must be carried out until a revolving cutting has been formed on both sides.
- Open the slides again, valve lever on: "BACKWARDS", switch off planer motor, remove planer and put it into the protection box.
Remove the produced cuttings without contacting the worked surfaces
- Close slides, valve lever on: "FORWARDS".
- Check pipe mismatch and gap on the joining pipe ends.
According to DVS 2207, the mismatch on the pipe outer side must not exceed 0.1 x pipe wall thickness, the admissible gap must not exceed 0.5 mm.
The mismatch compensation is carried out by further tightening or releasing of the clamping nuts.
In case mismatch compensation was carried out, planing must be repeated afterwards.
- The adjustment pressure for the pipe dimension to be welded can be gathered from the table. Add the movement pressure.
Set the resulting pressure value at the pressure limiter valve and check it by actuating the valve lever.
- Open slides again slightly, valve lever on: "BACKWARDS".
- Gather heating time, maximum change-over time, cooling down time and bead height for the pipe dimension to be welded from the table.
- Move the heating element, which has been cleaned and brought to nominal temperature, with the handle showing upwards between the pipes, if necessary wait, until the control lamp on the heating element is blinking in regular intervals.
- Close slides smoothly, valve lever on: "FORWARDS", to the set adjustment pressure.
When the prescribed revolving bead height is reached, reduce pressure. For this purpose, move the valve lever to position "Pressure release" until the desired heating pressure is built up (heating pressure = approx. 10% of the adjustment pressure).
- The heating time starts now. Press the stop-watch and compare the actual time with the nominal time taken from the table.
- After expiration of the heating time, open the slides, valve lever on: "BACKWARDS", remove the heating element as quickly as possible, put it into the protection box and close the slides smoothly, valve lever on: "FORWARDS".
The maximum time frame for this process is predetermined by the value for the change over time taken from the table.
- When the welding pressure is built up, press the stop-watch and keep the control lever for approximately 10s on position "FORWARDS" so that the hydraulic accumulator can be filled.
During the cooling time re-adjust pressure, if necessary (the pressure for cooling is the same as the set adjustment pressure).
- After expiration of the cooling time, release pressure, valve lever to position "Pressure release".
- Open the clamping devices and remove the welded part.
- Open the slides, valve lever on: "BACKWARDS".

6. Welding log and tables



You can access our website and select our welding tables via the qr code shown here. Select "WIDOS 4400" and the corresponding material (PE / PP /PVDF).

7. Maintenance and repair

Goal of the chapter is:

- Keeping the nominal state and the operation capacity of the machine.
- Increasing the efficiency by avoiding non-planned outage.
- Efficient planning of the maintenance works and the maintenance tools.

7.1. Maintenance and inspection, repair



All maintenance and repair works have to be basically performed with the machine in off position.

During this the machine has to be secured against unauthorized switching on.

Prescribed maintenance and inspection works should be performed in time.

The DVS gives the advice of inspection works after 1 year.

For machines with a specially high usage percentage the testing cycle should be shortened.

The works should be performed at the WIDOS GmbH company or by an authorized partner.

7.2. Clamping elements

- For a long service life clean and grease regularly the threaded spindles and the joint parts which are used for clamping the pipes.

7.3. Planer

- Check the stress of the drive chain in the planer and grease it regularly. Dismount the cover for that purpose.
- Do not lay the planer on its blades.
- Check the blades of the planer for sharpness, turn them if necessary (grinded on both sides, max. thickness of the shavings: 0,2 mm!).
- Check the function of the safety micro switch.

7.4. Storage

- The cylindrical waves of the basic machine are to be kept free from dirtiness and need to be covered with a thin oil film if they are not being used.
- Store dry.

7.5. Used hydraulic oil

Only use **HLPD 32**.

Features: protection against corrosion, resistance to ageing, abrasion-reducing additives, high carrying capacity and particulary water retending.

The hydraulic oil has to be disposed of properly.

7.6. Checking the hydraulic oil-level

- Unscrew the red cover screw on the top of the aggregate. Remove the integrated oil dipstick, clean it with a dry tissue and insert it again in the tank by screwing. Remove the oil dipstick again and check the oil level.
- The oil level must be between the two marks. If the oil level is under the lower mark, then hydraulic oil of the quality HLDP 32 must be added.

7.7. Venting the hydraulic cylinders

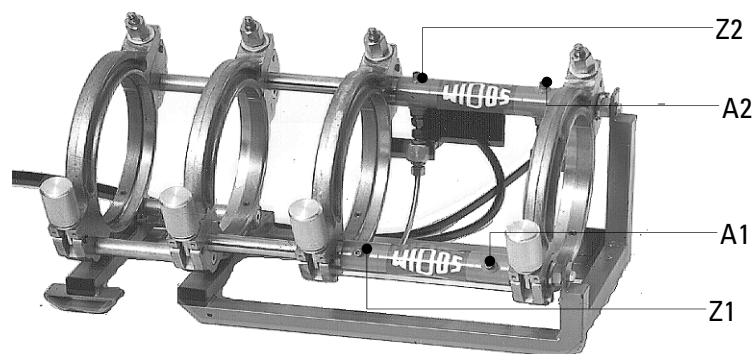

- Venting the hydraulic cylinder is not required if
 - the hoses have been disconnected from the quick-action couplings at the control unit because the remaining oil in the hose is being kept by valves and for this reason no air can enter.
- The hydraulic cylinder **must be vented** if
 - there has been too less oil in the tank and air has been attracted.
 - there were leaky parts at the hoses or in the connections.
 - the hoses were unscrewed from the basic machine.
- Eliminate the cause of the air entrance.
- Open the machine completely.
- First unscrew the lower „vent screw (Z1) for closing“ (lefthand side).
- Connect the transparent venting hose and insert it in the collecting vessel of the aggregate.
- Close until there is no more air visible in the venting hose, then tighten again the vent screw.
- Close the machine completely.
- Unscrew the lower „vent screw (A1) for opening“ (righthand side).
- Connect the transparent venting hose and insert it in the collecting vessel of the aggregate.
- Open until there is no more air visible in the venting hose, then tighten again the vent screw.
- When the venting process at the lower vent screws is completed, repeat the process at the upper „vent screw (Z2) for closing“ (lefthand side), as well as at the upper „vent screw (A2) for opening“ (righthand side).



The lower vent screws always have to be vented at first because there is a direct connection between the upper and the lower cylinders.

- If air remains in the lower cylinder, it will ascend in the upper cylinder when pressure is applied.

8. Transport

The machine can be transported in a packing box.

The packing box contains the basic machine, the aggregate, the reduction inserts and the reception box with planer and heating element.

- In the box holders are included which are suitable for each single component in order to avoid slipping
 - Put the components into the box in such a way that they fit in the holders.
- The hydraulic hoses at the basic machine should not be unscrewed (air penetration).
 - Make sure they are not squeezed.
- Handle the machine carefully.
 - Do not tilt the aggregate too much. Otherwise there is the danger that oil may come out.
 - Protect the machine from heavy shocks and impacts.
 - Make sure the box cover is closed correctly.
- During the construction of the transport box a stress was put on a light-weight construction.
- Take much care when using automatic handling and carrying machines.



During the transport of the machine there may be cold weldings between the piston rod and the eyes of the planer housing.

These spots on the piston rod may damage the sealing. Therefore the eyes must be lubricated with PTFE-spray before each transport!

9. Hydraulic and electric diagrams

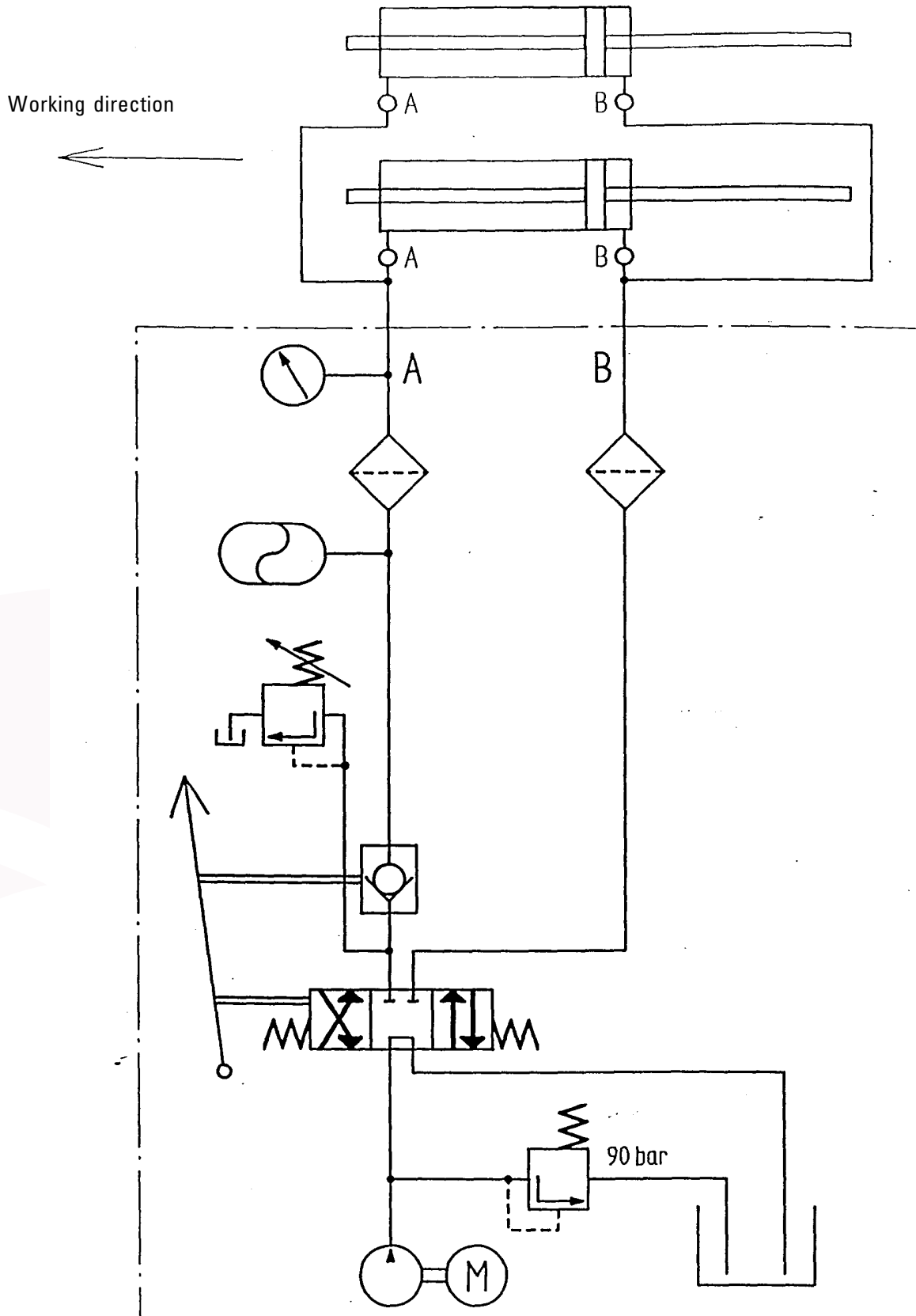

Hydraulic diagramm

1 2 3 4 5 6 7 8

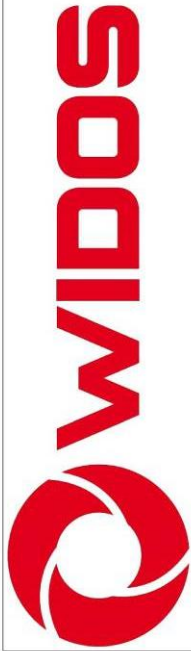

WIDOS GmbH
 Kunststoffschweißtechnik
 Plastic Welding Technology

Einsteinstrasse 5
 D-71254 Ditzingen
 Tel.: +49 (0) 7152 / 9939-0
 Fax: +49 (0) 7152 / 9939-40
<http://www.widos.de>

circuit diagram

project designation 4400 manuell

machine type 4400 manuell

number of sheets 2
 Date 02.11.18

Copying or passing on only with our written permission allowed.

commission	Date	02.11.18	4400 manuell	project designation	4400 manuell	= 000XU
	2 draughtsman	Bouhjar				
number of sheets	Date	09.11.18	cover sheet	job number	4400_2018_EN	+
date of print	chk.	02.11.18		drawing number		sheet number
project status						confirmation sheet
						number of sheets
						1
						2

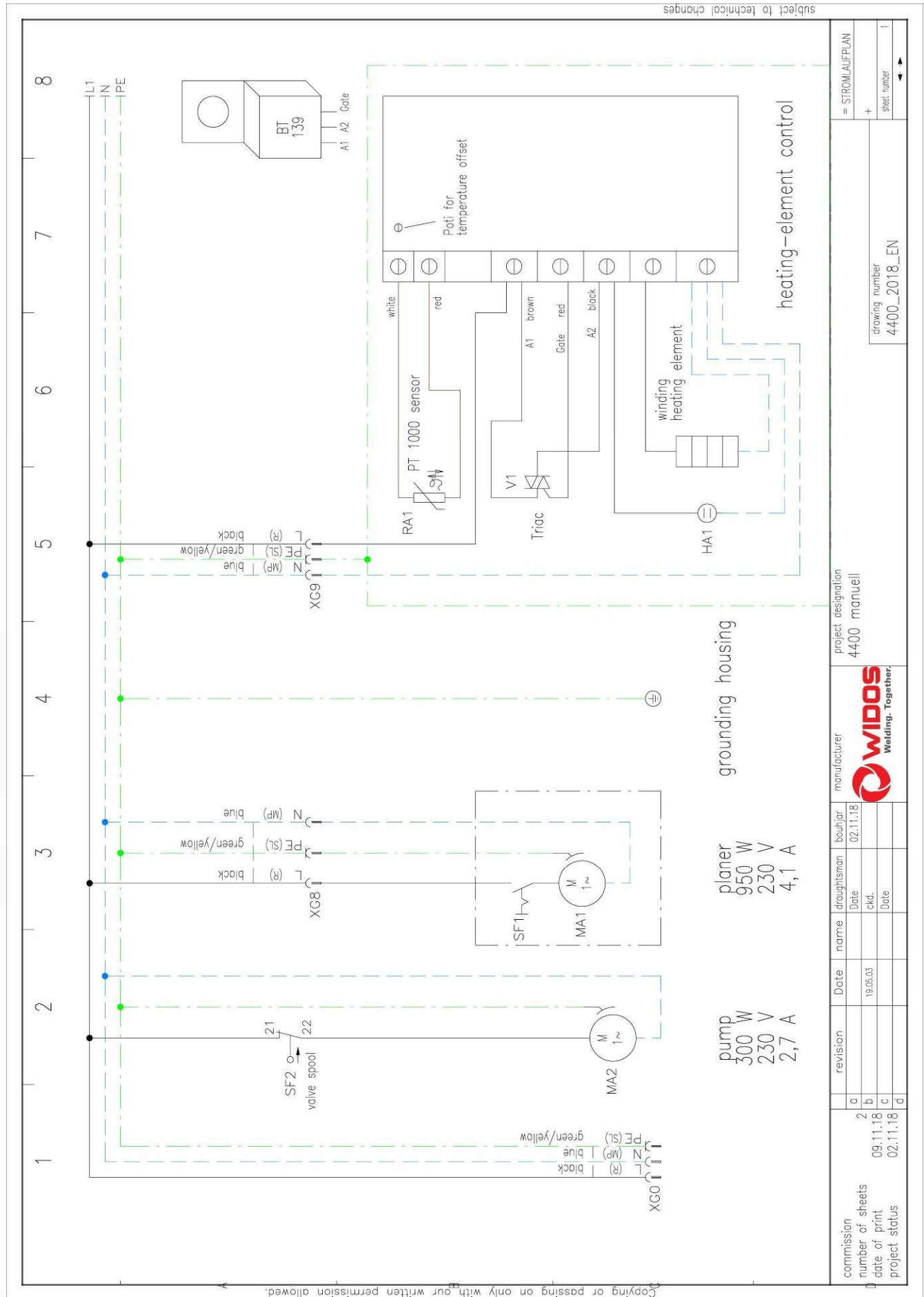

subject to technical changes

commission	revision	Date	name	draughtsman	bohrer	manufacturer	project designation
number of sheets	a				02.11.18	WIDOS	4400 manuell
date of print	b	19.05.03				Welding. Together.	
project status	c						
	d						
							drawing number
							4400_2018_EN
							sheet number
							1

10. Spare parts list



You can access our website and select our spare parts lists via the qr code shown here. Select "4400"

11. Declaration of conformity

Issuing the declaration of conformity with regard to complying with the basic requirements and assembling the technical documentation is in the sole responsibility of:	
Manufacturer / Installation company:	WIDOS Wilhelm Dommer Söhne GmbH
Address:	WIDOS GmbH Einsteinstr. 5 D-71254 Ditzingen

Subject of the present declaration is the following device:	
<i>Product name:</i>	Heating element butt welding machine
<i>Model name:</i>	WIDOS 4400
<i>Machine number:</i>	
<i>Year of construction:</i>	

For the stated device we herewith declare that it complies with the basic requirements stipulated in the following designated harmonizing regulations:
in the sense of the EC guideline EC-Machinery Directive 2006/42/EC

Statement of the relevant harmonizing standards referred to, or indication of the specifications that the conformity is declared for:	
Standard	Title
DIN EN ISO 12100	Safety of machines, basic concepts, general layout guidelines
DIN EN ISO 4413	Fluid technology, general regulations and safety-related requirements of hydraulic appliances
DIN EN 60204.1	Electrical equipment of industrial machinery
DIN EN 60555 / DIN EN 50082 / DIN EN 55014	Electromagnetic compatibility

Entitled to compile the technical documentation:	
Name:	WIDOS Wilhelm Dommer Söhne GmbH
Address:	Einsteinstr. 5 D-71254 Ditzingen

Signed on behalf of the company:	
Name, first name:	Dommer, Martin
Function:	Technical director



Heimerdingen, 16.05.2019

Place / Date

Legally binding signature

This declaration is to certify the compliance with the mentioned harmonizing regulations, however does not include any assurance of properties.